BETA MARINE

Mid Diesel Engine Range



Heat Exchanger Cooled 43 to 150 hp
All the power you need

Why Beta?

Because:

- We have a superb heat exchanger cooled engine range especially engineered for the yachtsman and work boats at an affordable price, and with a 3 year 'self service' warranty.
- With our Dealer network and dedicated seagoing team, we have probably installed a Beta engine in a yacht similar to yours. Ask for details!
- Special Engine Feet option - designed and manufactured to suit your engine bearers.
- Low carbon foot print - these clean engines meet all current and projected exhaust emission regulations - both **RCD** (Recreational Craft Directive 94/25/EC as amended by 2003/44/EC) and **EPA** (U.S Environmental Protection Agency) exhaust emission compliance.
- Our Mid engine range is based upon the most technically advanced Kubota diesels that give you very smooth, quiet power, right through the speed range. The Beta 150 is very similar, based on an IVECO diesel.
- Easy maintenance with mounted sump pump and optional polyvee belt & pulley drive transmission with our high output alternators.
- Beta Engines are built in Gloucestershire, U.K.
- See our website for more details:
www.betamarine.co.uk

Beta's Gloucester manufacturing facility

Seagoing Specifications

Beta Marine's Seagoing engines are:

- Heat Exchanger cooled, naturally aspirated marine diesel engines based on Kubota.
- Multi cylinder with high inertia flywheel for smooth running.
- Three vortex combustion for quiet running, low emissions and excellent fuel consumption with indirect injection up to and including 75 hp.
- Quiet gear driven camshaft for engine reliability and easy servicing – no timing chains or tooth belts to replace.
- Water cooled exhaust manifold.
- Battery charging alternator - 65 amps, giving full power at cruising speed with 12 volt electric starting as standard.
- Heater plugs for cold start below 5°C.
- Direct injection – Beta 90 and Beta 150.
- Standard "ABV" Control Panel.
- Heavy duty feet and flexible mountings.
- PRM Marine, or Technodrive, ZF gearbox with 2:1 reduction ratio as standard; Output rotation is clockwise in ahead, viewed from gearbox end.
- Fuel filter and mechanical fuel lift pump.
- Lubricating oil filter and sump drain pump.
- 'Morse' type engine speed and gearbox control cable support and end fittings.
- Installation angles up to 15° maximum when static and 25° when heeling (Kubota).

Seagoing Options

- Control Panel ABVW, B, Deluxe 'C' options with gauges and alarms
 - Down angle and Vee Drive gearbox options.
 - Calorifier connections for hot water systems.
 - Larger 100 amp alternator and possible second alternator 12 volt x 150 amp or 24 volt plus Travel Power 3.5 kVA or 5 kVA - 230 Volt - options.
 - Hydraulic Propulsion engine package and/or bow thrusters.
- Many more – see our price list!



Beta 43

4 Cylinders - 1999cc - 43hp max at 2,800 rev/min - 253Kg

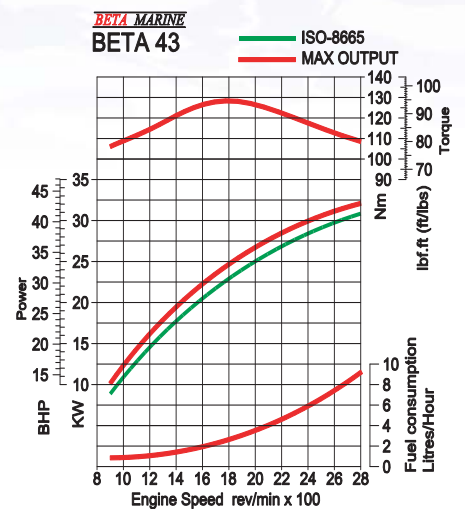
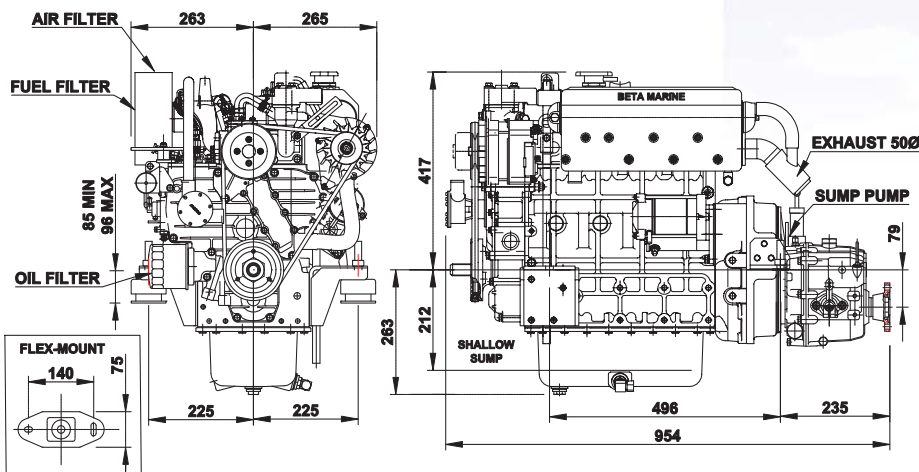
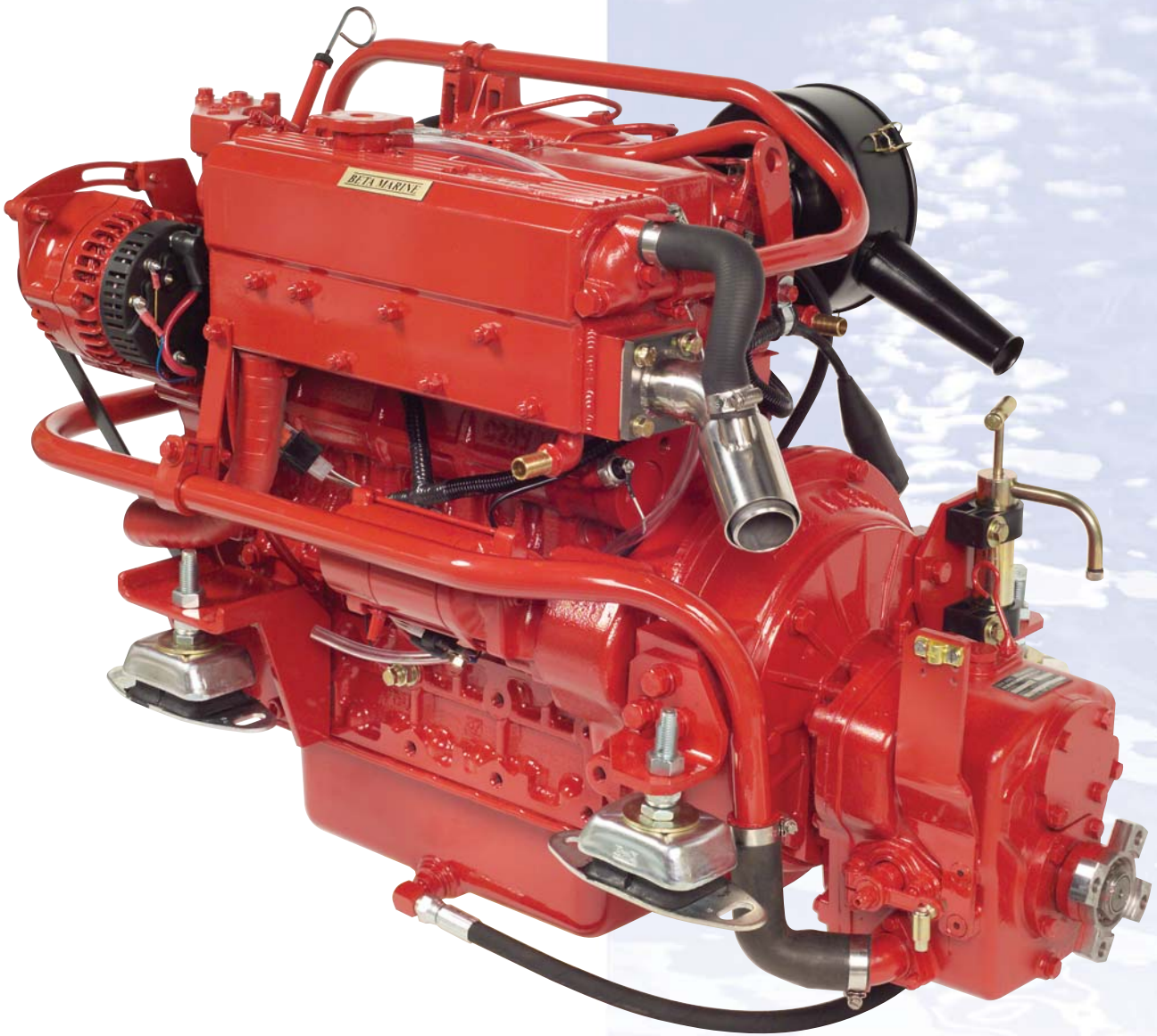

FUEL CONSUMPTION BASED ON THEORETICAL PROPELLER LOADING - MATCHED AT FULL SPEED.

Beta 50

4 Cylinders - 2197cc - 50hp max at 2,800 rev/min - 260Kg

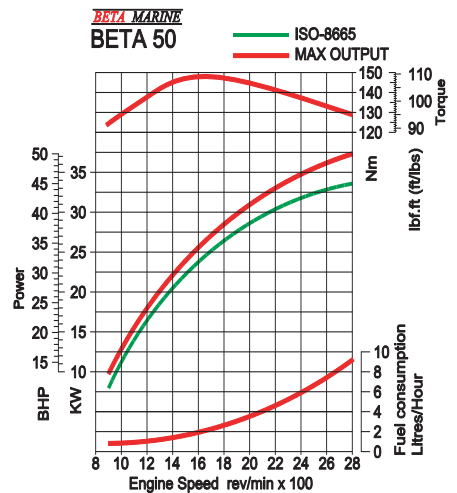
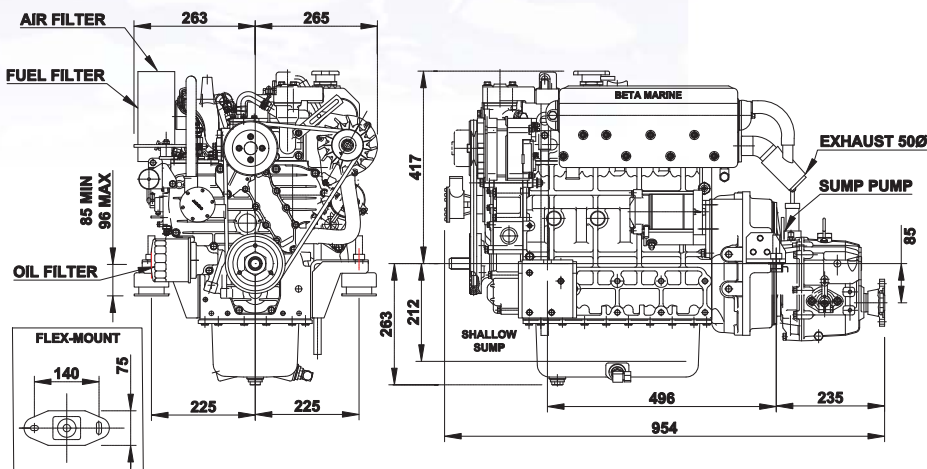
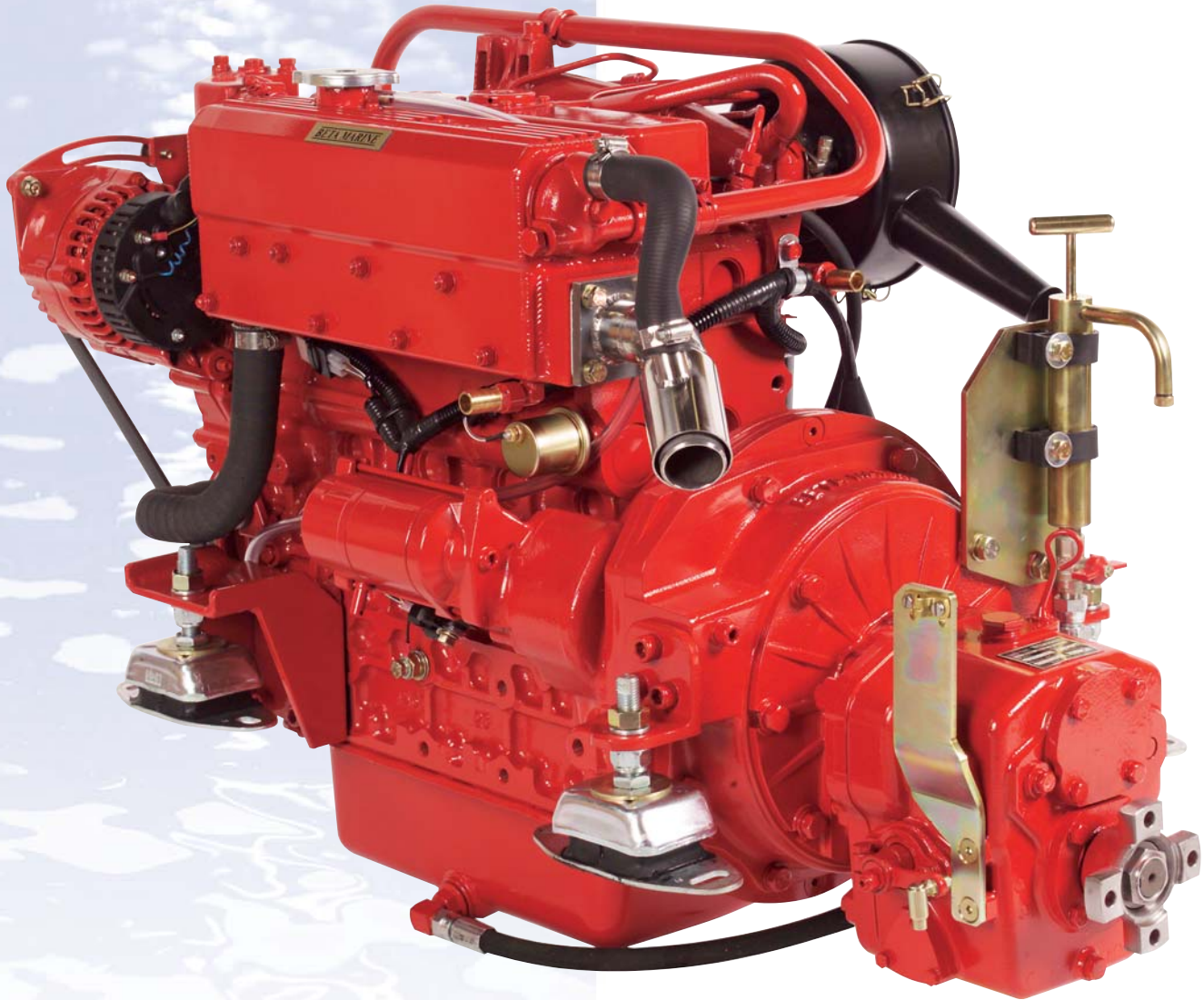

FUEL CONSUMPTION BASED ON THEORETICAL PROPELLER LOADING - MATCHED AT FULL SPEED.

Beta 60

4 Cylinders - 2434cc - 56hp max at 2,700 rev/min - 287Kg

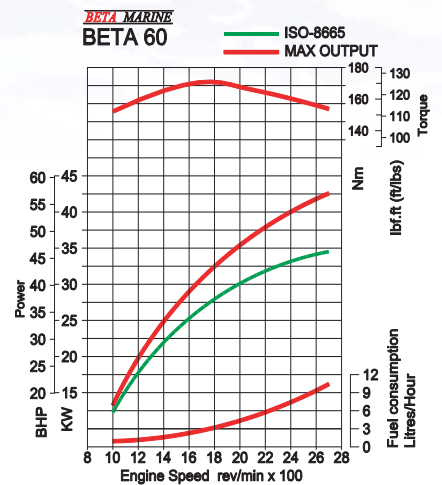
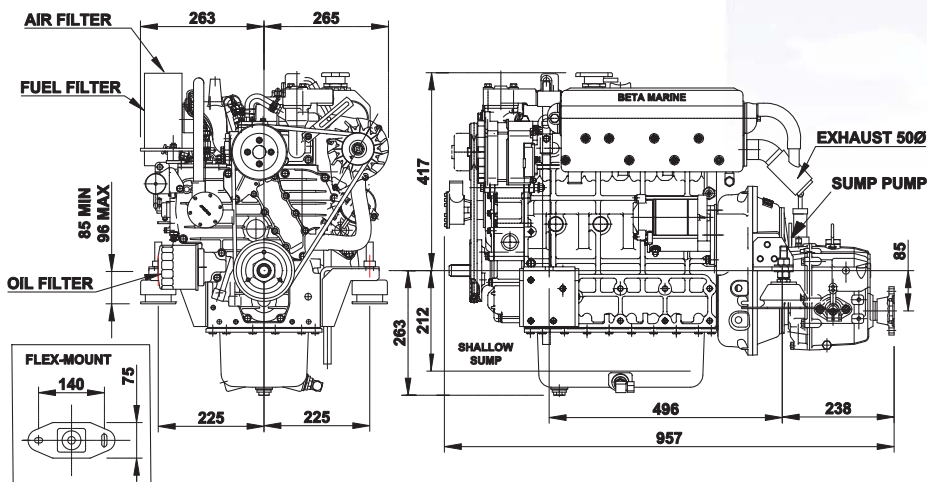
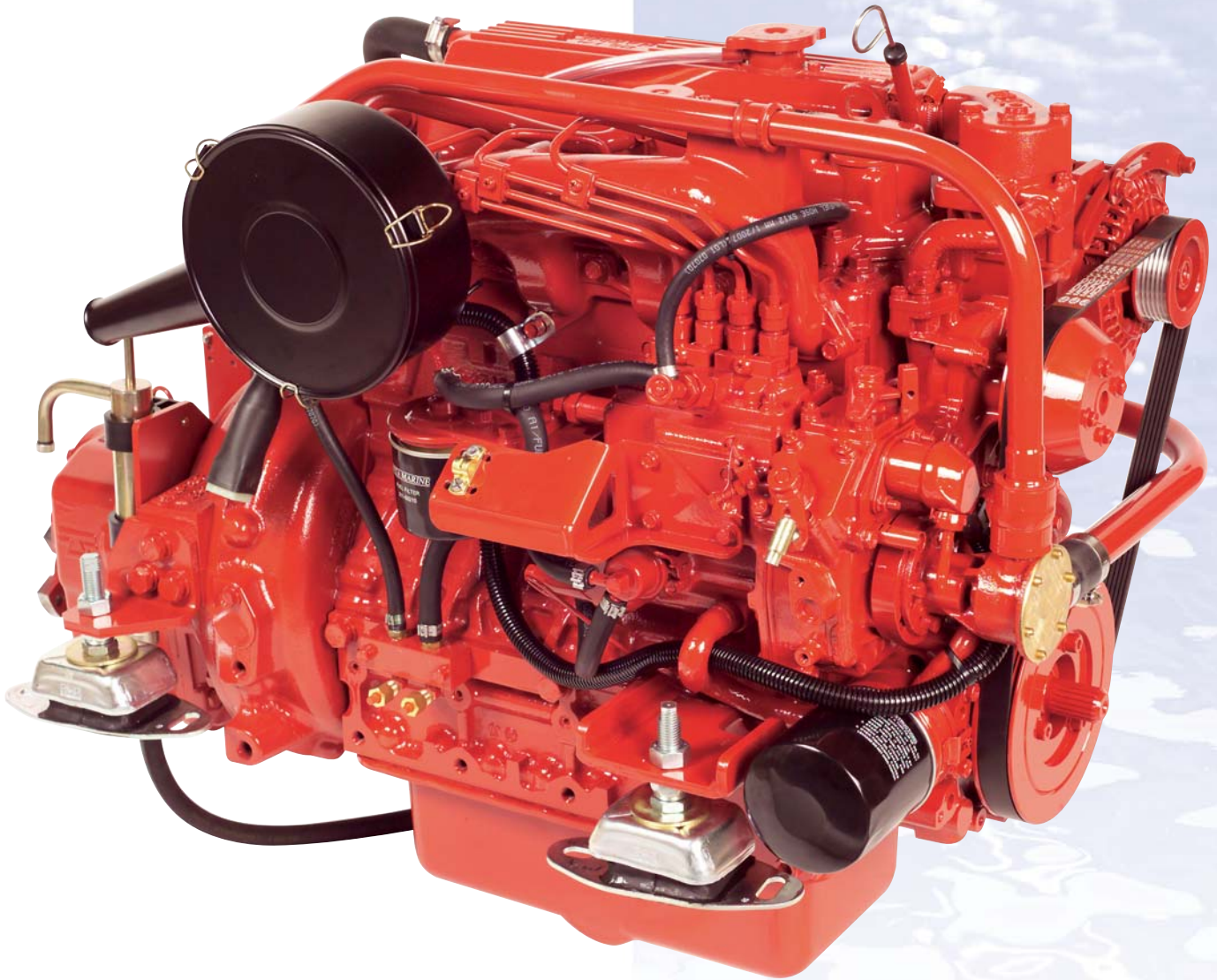

FUEL CONSUMPTION BASED ON THEORETICAL PROPELLER LOADING - MATCHED AT FULL SPEED.

Beta 75

4 Cylinders - 3620cc - 75hp max at 2,600 rev/min - 414Kg

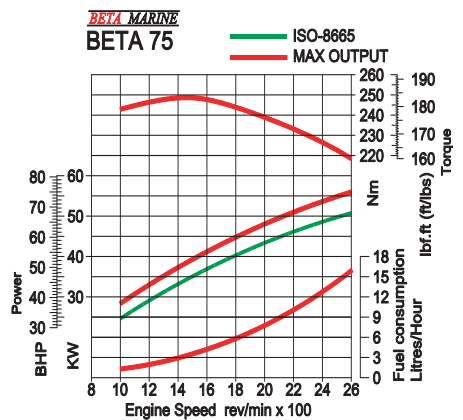
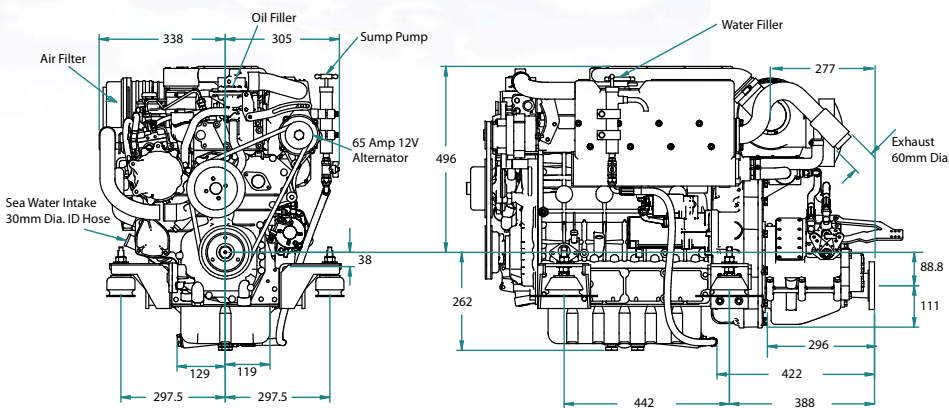
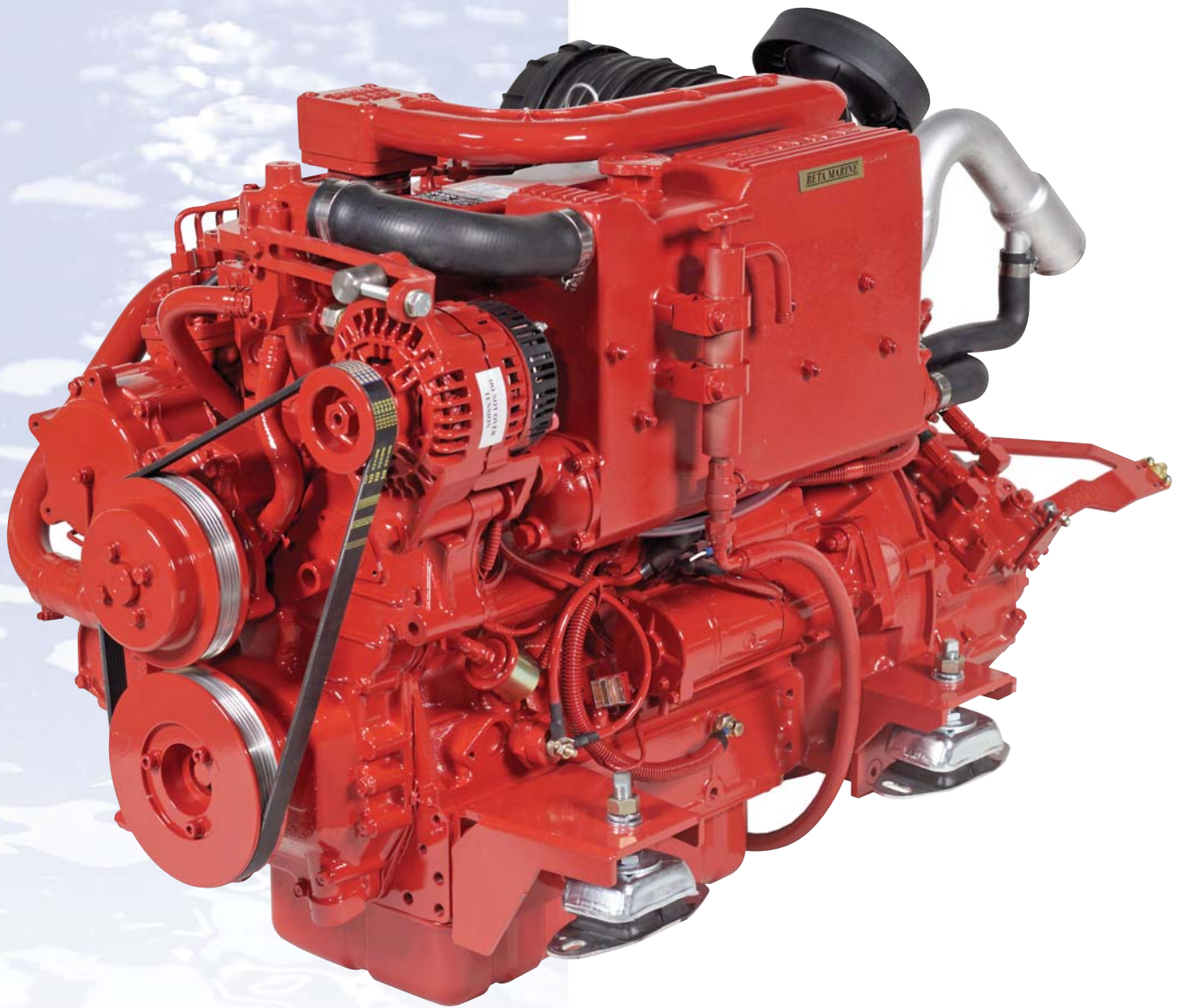

FUEL CONSUMPTION BASED ON THEORETICAL PROPELLER LOADING - MATCHED AT FULL SPEED.

Beta 90

4 Cylinders - 3769cc - 90hp max at 2,600 rev/min - 425Kg

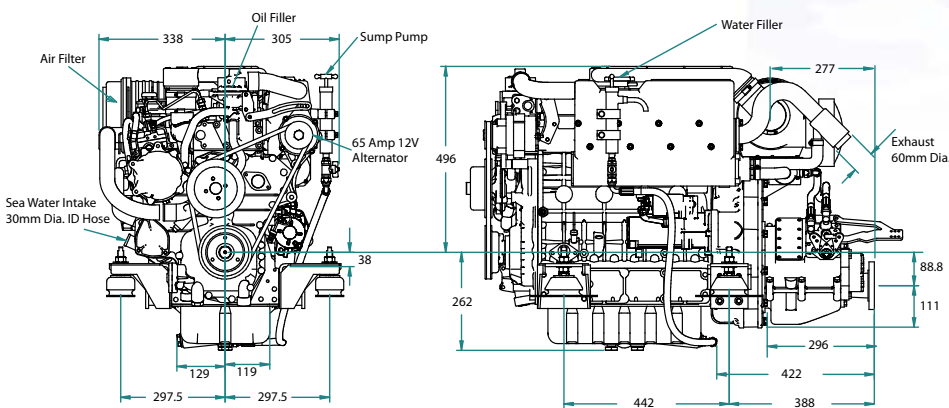

BETA MARINE
BETA 90

ISO-8665
MAX OUTPUT

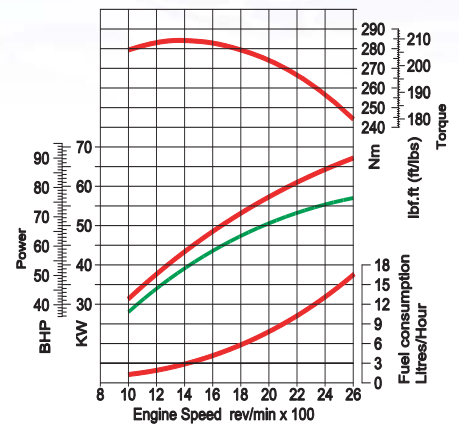

FUEL CONSUMPTION BASED ON THEORETICAL PROPELLER LOADING - MATCHED AT FULL SPEED.

This engine is 'Recreational Craft Directive' emission compliant, but not EPA compliant.

Beta 150

6 Cylinders - 6.7 litre - 147bhp max at 2,800 rev/min - 680Kg

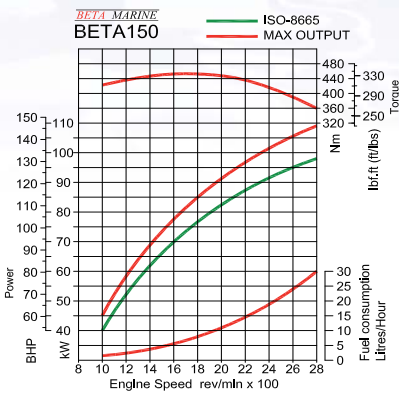
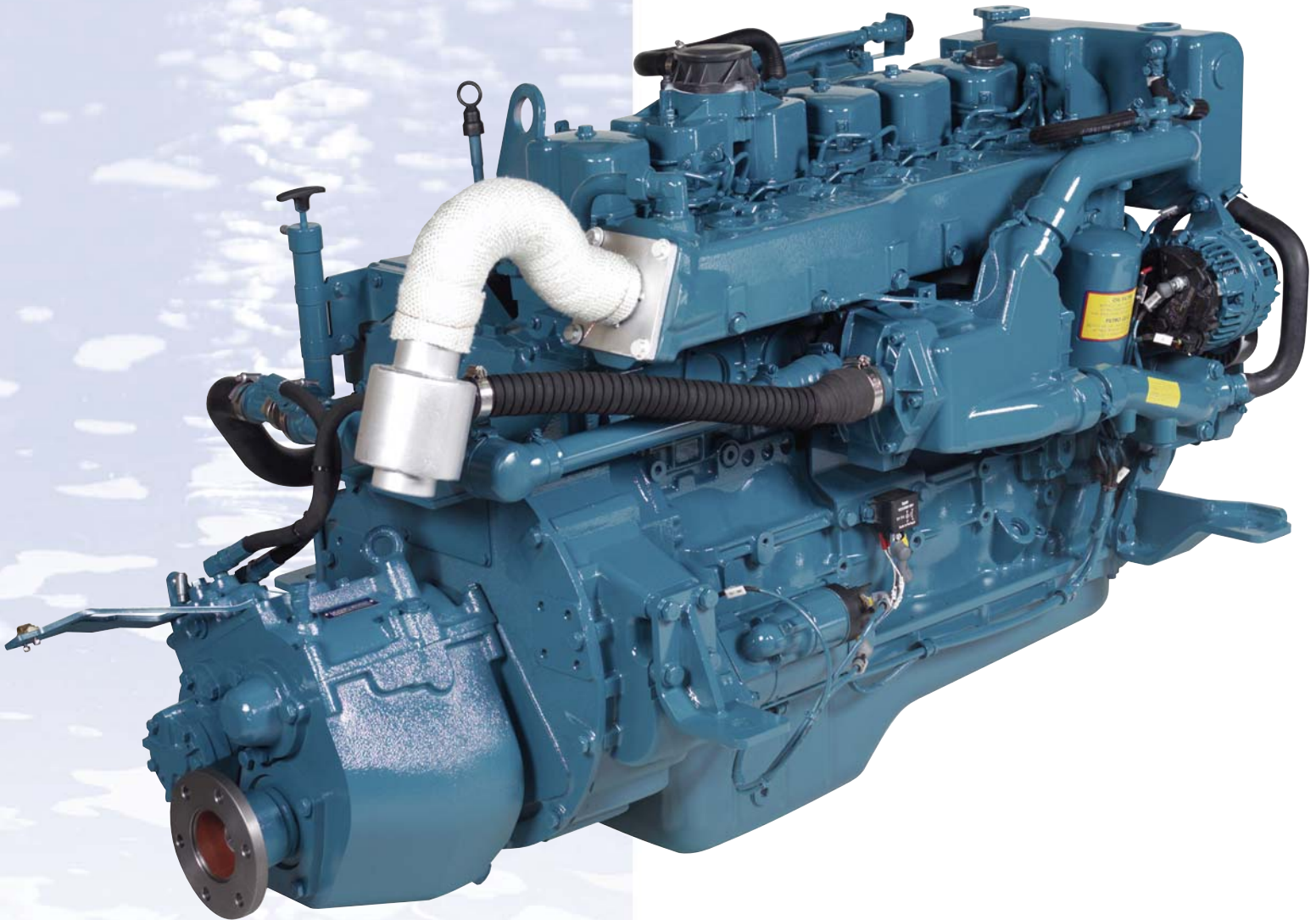

FUEL CONSUMPTION BASED ON THEORETICAL PROPELLER LOADING - MATCHED AT FULL SPEED.

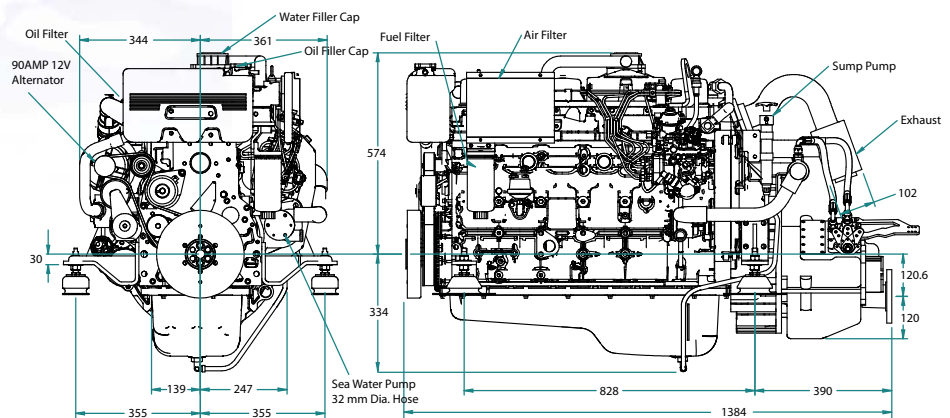

The Beta 150 has been specially developed for commercial Fishing Boats, Launches, Wide Beamers and Dutch Barges. It is a heavy duty - 6 cylinder - naturally aspirated - direct injection - marine propulsion diesel engine. Its outstanding asset is the slow speed / high torque of 440Nm developed at 1400 rev/min from an engine of solid construction that is not only smooth and quiet but also economic with direct injection. This engine is 'Recreational Craft Directive' emission compliant, and EPA compliant.

Control Panels



Standard 'ABV' Control Panel

Tachometer with running hour recorder, keystack switch, push button stop, green light for 'power on', red warning lights and audible alarm for: low oil pressure, high water temperature, domestic and engine alternators 'no charge'; 3m interconnection cable with multi pin plug connector.



Optional 'ABVW' Control Panel

Tachometer with running hour recorder, waterproof push buttons for heat/start/stop, green light for 'power on', red warning lights and audible alarm for: low oil pressure, high water temperature, domestic and engine alternators 'no charge'; 3m interconnection cable with multi pin plug connector.



Optional 'B' Control Panel

Tachometer with running hour recorder, water temperature gauge, keystack switch, push button stop, green light for 'power on', red warning lights and audible alarm for: low oil pressure, high water temperature, domestic and engine alternators 'no charge'; 3m interconnection cable with multi pin plug connector.



Optional 'C' Control Panel

Tachometer with running hour recorder, oil pressure and water temperature gauges, voltmeter, keystack switch, push button stop, green light for 'power on', red warning lights and audible alarm for: low oil pressure, high water temperature, domestic and engine alternators 'no charge'; 3m interconnection cable with multi pin plug connector.

Gensets for Yachts and Workboats

Beta Marine has gained considerable experience over many years manufacturing marine generating sets for yachts and work boats. These small marine generating sets are based on Kubota diesel engines from 34VA up to 50kVA; available as a standard generating set or acoustically housed.

- A Quality robust design - manufactured for reliable and dependable long life operation.
- Low noise levels as standard - Acoustic housings an option
- Heat Exchanger or Keel cooling
- Lloyds Register "Design Appraisal"
- 'Recreational Craft Directive 94/25/EC as amended by 2003/44/EC' emission compliant.
- Generating Set Warranty is 12 months from commissioning in accordance with our standard terms.

Our marine generating sets have high quality Acoustic housings that are carefully designed to have compact dimensions and low weight, with all service connections brought to the outside of the housing - ready for a quick and easy installation.

Beta Marine manufacture Marine generating sets up to 700 kVA with classification to Lloyds Register, DNV, Bureau Veritas, Germanischer Lloyd, ABS etc. We welcome your marine enquiries for main, stand-by, emergency sets and other marine auxiliary equipment.

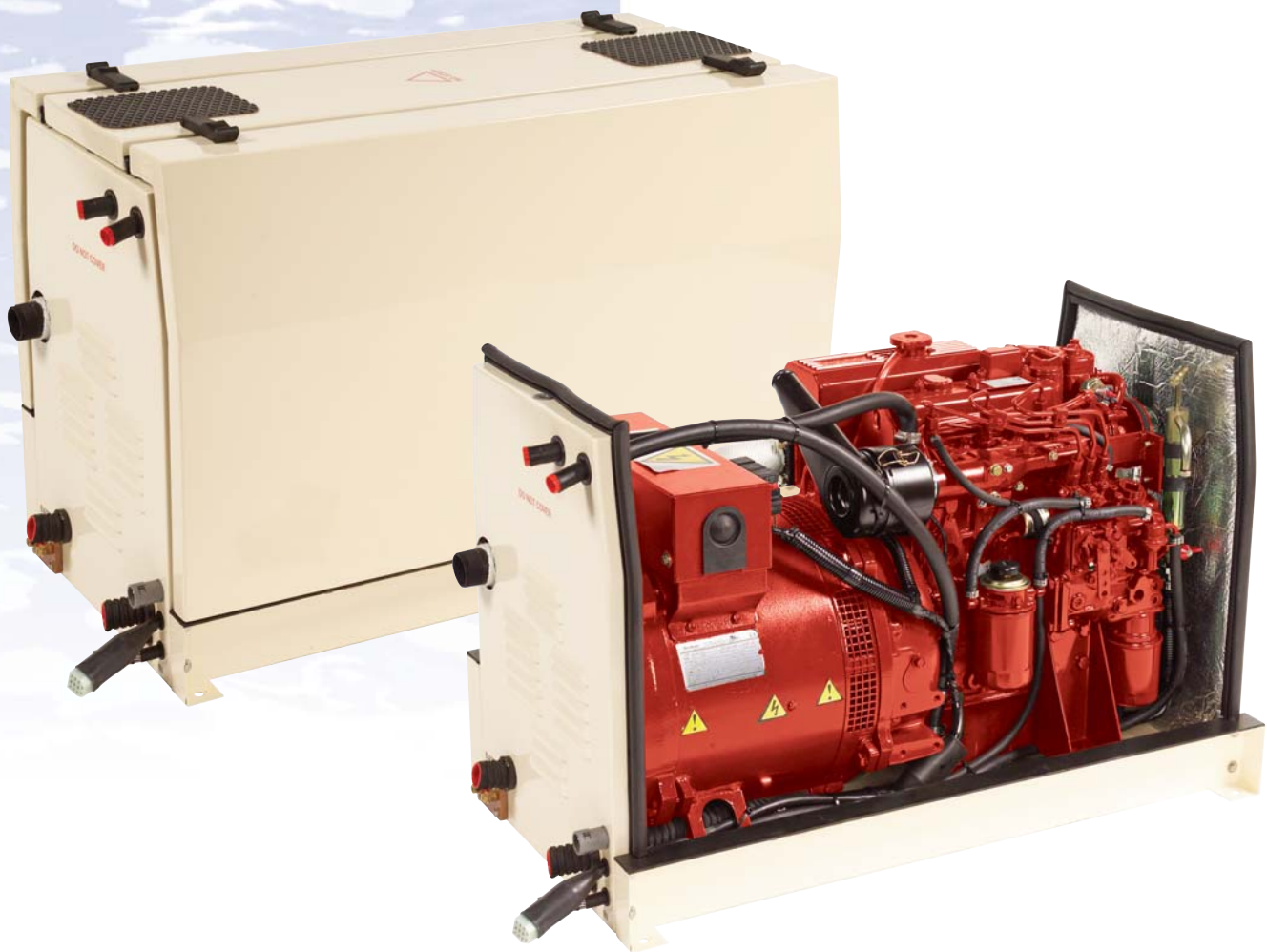

Re-Engining? - Special Feet

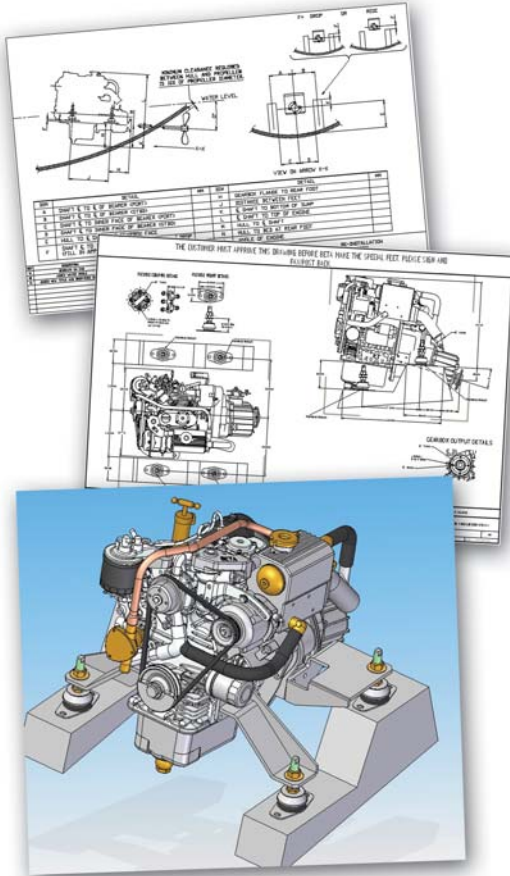

Are you replacing an old engine?

Beta engines have been fitted into thousands of yachts around the world with our standard engine feet; but where necessary we also offer our unique service of designing and manufacturing "Special Engine Feet" so that our engine just drops onto your existing engine bearers.

We have made hundreds of "Special Feet" over the years and in many cases can substantially reduce the time and installation costs.

The system works like this: we have a standard drawing where you just fill in the measurements of your existing engine bearers and propeller shaft position; we then prepare a finalised drawing for you to sign-off for us to manufacture your special feet. We then manufacture, fit and paint them so that your engine arrives ready to 'drop in'.

Hydraulic Propulsion Unit

We offer a standard range of high quality hydraulic propulsion engines. We would be pleased to discuss your hydraulic installation with you and offer technical assistance and a detailed quotation.



35 litre reservoir with suction boost valve

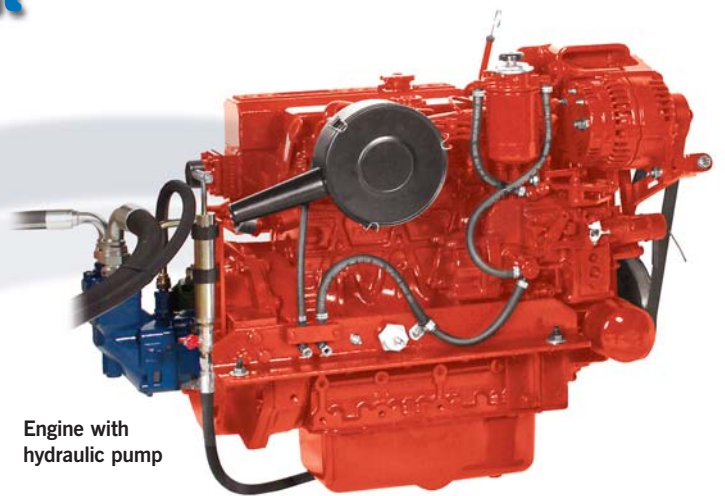

Engine with hydraulic pump



Hydraulic oil cooler



Directional control valve

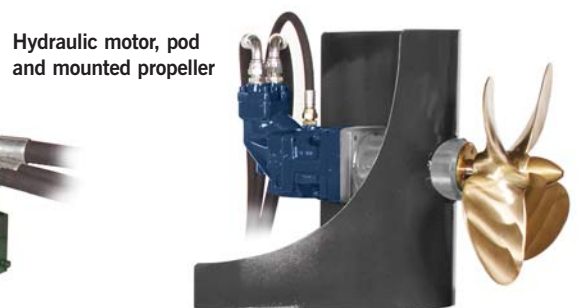

Hydraulic motor, pod and mounted propeller

BETA MARINE

the yachtsman choice...

- Advanced Engineering giving very low emissions
- Compact and quiet - they run like sewing machines
- National and International Dealer Support
- Large 70, 100 and 150 amp alternator options
- Special feet option - manufactured to suit your installation
- Heat Exchanger Cooled



*Beta 10
& Beta 14*



Beta 16



Beta 20



Beta 25



Beta 30

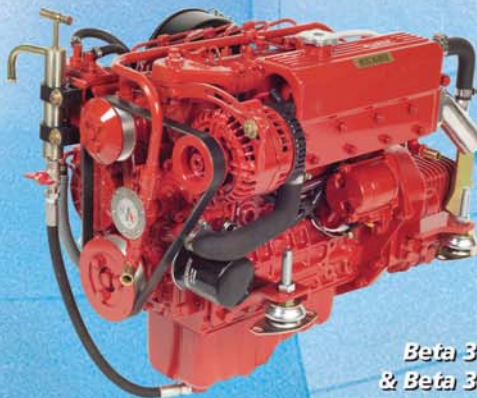

*Beta 35
& Beta 38*



*Beta 43,
Beta 50
& Beta 60*



*Beta 75
& Beta 90*



Beta 150



Saildrives

*Beta 14SD, Beta 16SD, Beta 20SD,
Beta 25SD, Beta 28SD, Beta 30SD,
Beta 38SD, Beta 43SD, Beta 50SD,
Beta 60SD*